

METAL CLAD WIRE WOUND RESISTORS

WD5, WD10, WD25, WD50,  
WD75, WD100, WD150,  
WD200, WD250, WD300

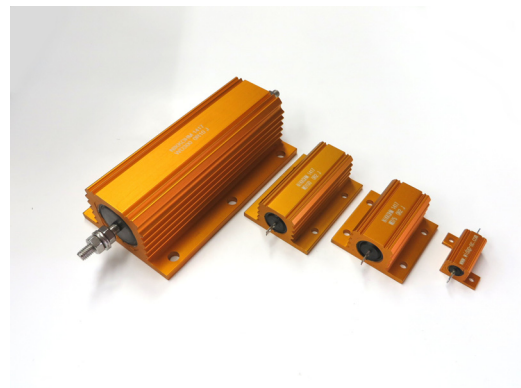

Features and Applications

Power rating 75W to 300W, rush current protection.

High temperature operation, -25°C to 250 °C and all welded construction. Low TCR 30ppm/K, Tolerance 5% in standard and available up to 0.25%.

Non-inductive winding is available, please call us

MIL-R-39009 and MIL-R-18546 style.

Applications include inverters for power electronics

Dimensions (mm)

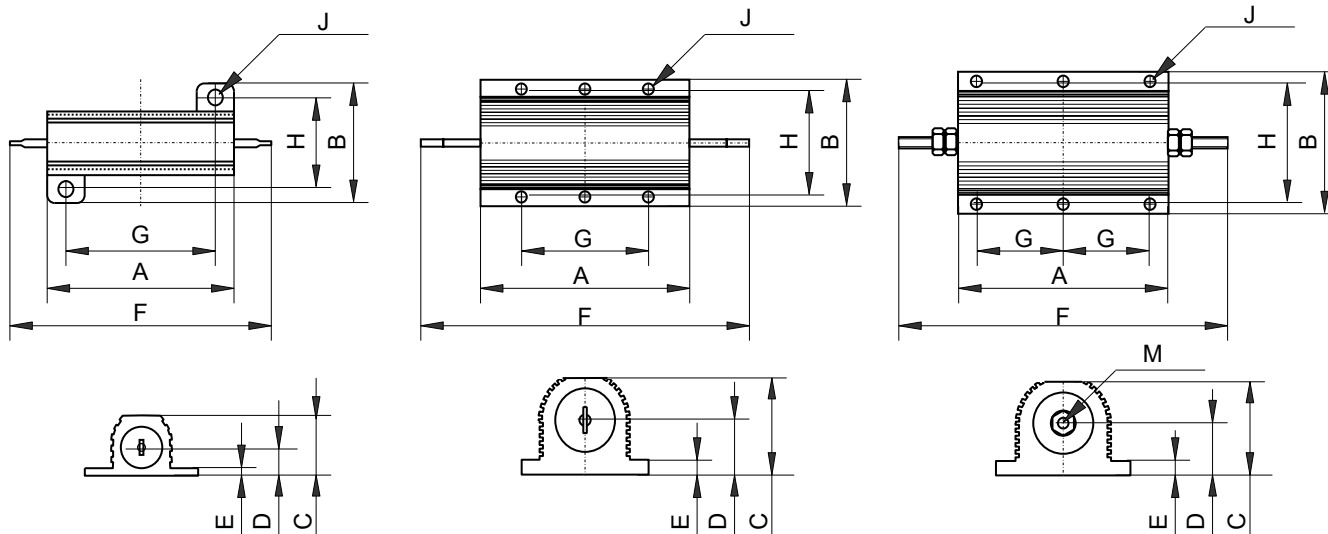

WD5, WD10, WD25, WD50

WD75, WD100, WD150

WD200, WD250, WD300

(mm)	A	B	C	D	E	F	G	H	J	M
	±0.5	--	Max	Max	--	Max	±0.3	±0.3	±0.5	--
WD5	16.8	17.0	9.0	4.5	2.5	31.0	11.3	12.4	2.4	--
WD10	20.1	21.0	11.0	5.5	2.5	36.5	14.3	15.9	2.4	--
WD25	27.3	28.0	15.0	7.5	3.0	51.8	18.3	19.8	3.2	--
WD50	50.1	30.0	17.0	8.5	3.0	72.5	39.7	21.4	3.2	--
WD75	48.9	48.0	26.0	12.0	4.0	71.0	29.0	37.0	4.4	--
WD100	65.4	48.0	26.0	12.0	4.0	87.5	35.0	37.0	4.4	--
WD150	97.0	48.0	26.0	12.0	4.0	122.0	29.0	37.0	4.4	--
WD200	89.0	73.0	45.0	20.5	5.5	143.0	35.0	57.2	5.1	M6
WD250	114.0	73.0	45.0	20.5	5.5	163.0	44.5	57.2	5.1	M6
WD300	127.0	73.0	45.0	20.5	5.5	180.0	52.0	59.0	6.6	M6

METAL CLAD WIRE WOUND RESISTORS

WD5, WD10, WD25, WD50, WD75, WD100, WD150, WD200, WD250, WD300

Power Rating and Resistances

Type	Power Rating(W @ 25°C)		Resistances	Operating Voltages	Insulation Voltages	Weight	Heat Sink Plate
	With heat sink	Without heat sink	Resistance Range Ω	DC / AC rms Volt	(AC peak Volt)	Weight approx. (grams)	cm <sup>2</sup> - thickness mm
WD5	10	5	0.01 - 10k	160	1400	5	400 - 1
WD10	15	8	0.01 - 15k	260	1400	7	400 - 1
WD25	25	12.5	0.01 - 33k	550	2500	15	550 - 1
WD50	50	20	0.01 - 86k	1250	2500	30	550 - 1
WD75	75	45	0.01 - 50K	1400	5000	85	1000 - 3
WD100	100	50	0.01 - 100K	1900	5000	115	1000 - 3
WD150	150	55	0.01 - 100K	2500	5000	175	1000 - 3
WD200	200	50	0.01 - 50K	1900	5000	475	3750 - 3
WD250	250	60	0.01 - 65K	2200	5000	600	4800 - 3
WD300	300	75	0.01 - 80K	2500	5000	700	5800 - 3

Ordering Information

Model WD75	Resistance 50ohm	Tolerance 5%, J	Package Code Z00
WD5	any value	0.25%, C	Bulk and Z: RoHS 2
WD10	in above range	0.50%, D	
WD25 / WDN25		1.00%, F	
WD50 / WDN50		5.00% J, STD	
WD100 / WDN100			
WD150 / WDN150			
WD200 / WDN200			
WD250 / WDN250			
WD300 / WDN300			

For non-inductive windings, please attach 'N' after 'WD' as 'WDN'  
 Non-inductive windings are available on minimum resistance 0.1Ω or more.  
 Only inductive is available for WD5 and WD10.

Derating

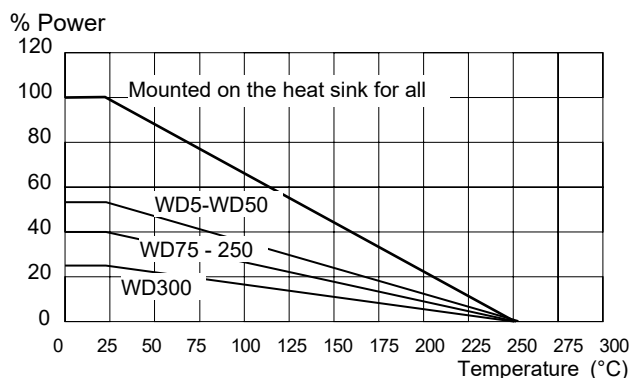

Temperature Rise

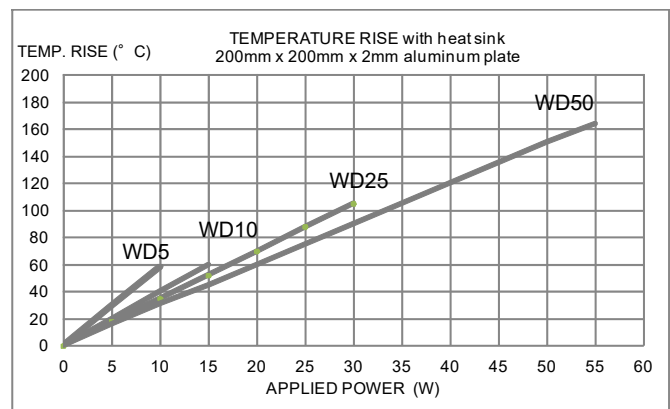

Specifications and Performances

抵抗値許容差	Tolerance	(for values less than 1Ω) (for values greater than 1Ω)	+/-5% in standard +/-0.25% to +/-5% available
抵抗温度係数	TCR	Dry / Normal	100 ppm/°C
絶縁抵抗	Insulation Resistance	Dry / Normal	10 GΩ min.
負荷寿命	Load Life	90min ON, 30min OFF 1000 H	ΔR < 1%+0R05
短時間過負荷	Short time Overload	5 x rated voltage for 5 seconds	ΔR < 1% +0R05
端子強度	Terminal Strength	20N Pull	ΔR < 0.25% +0R05
はんだ耐熱性	Resistance of soldering Heat	260 °C 10 seconds	ΔR < 0.25% +0R05
熱衝撃	Thermal Shock	-55 °C - +200 °C, 5 cycles	ΔR < 0.25% +0R05
耐振性	Vibration	10Hz to 500Hz, 10g, 6 hours	ΔR < 0.25% +0R05